



GUIDE SPECIFICATION
FOR INSTALLATION
AND STORAGE OF
HOLLOW METAL
DOORS AND FRAMES



This manual was developed by representative members of the Hollow Metal Manufacturers Association Division (HMMA) of the National Association of Architectural Metal Manufacturers (NAAMM) to provide information and guidance on the installation and storage of hollow metal doors and frames. This manual contains advisory information only and is published as a public service by NAAMM and its HMMA Division.

NAAMM AND ITS HMMA DIVISION DISCLAIM ALL LIABILITY OF ANY KIND FOR THE USE, APPLICATION OR ADAPTATION OF MATERIAL PUBLISHED IN THIS STANDARD.

Purchasers of NAAMM Standards may receive current information on all NAAMM Standards by calling or writing the National Association of Architectural Metal Manufacturers, or by visiting our website at www.hollowmetal.org.

National Association of Architectural Metal Manufacturers

800 Roosevelt Road

Bldg. C, Suite 312

Glen Ellyn, Illinois 60137

Phone: (630) 942-6591 Fax: (630) 790-3095

www.naamm.org

Copyright © 2007

National Association of Architectural Metal Manufacturers

All Rights Reserved

TABLE OF CONTENTS

Part 1 - INTRODUCTION

A. Related Documents	1
----------------------------	---

Part 2 - RECEIVING AND STORAGE OF MATERIAL

A. Receiving Material.....	1
B. On Site Storage	1

Part 3 - INSTALLATION OF FRAMES

A. General	3
B. Prior to Installation.....	3
C. Installation Tolerances	3
D. Typical Installation Procedures.....	5
E. Wall Constructions and Appropriate Anchors	9
1. Masonry Walls	10
2. Steel Stud Walls.....	11
3. Wood Stud Walls.....	13
4. Existing Masonry Walls.....	14
5. Completed Drywall.....	15
F. Grouting of Frames	16
G. Field Splicing	16

Part 4 - HANGING OF DOORS

A. General	17
B. Operation Clearances	17
C. Care After Installation	17

Part 5 - APPENDIX

A. Grouting Hollow Metal Frames	A1
B. Defining Undercuts.....	A2
C. Painting Hollow Metal Products.....	A4

STORAGE AND INSTALLATION OF HOLLOW METAL DOORS AND FRAMES

PART I - INTRODUCTION

This guide specification is intended to stress the necessary precautions and requirements for receipt, storage, handling and installation of hollow metal products, and the skills essential in the hanging of doors.

The proper performance of most products depends not only on how they are manufactured, but how they are installed. This is especially true of hollow metal doors and frames. The installation of doors and frames is an operation demanding care and skill, if the doors are to operate properly. Care in manufacturing does not, in itself, guarantee satisfactory performance. Even the best designed and most carefully constructed frames and doors, if incorrectly installed, will not function properly.

Hollow metal work is fabricated in accordance with the shop drawings, approved by the architect or engineer. Preparation for hardware or other items supplied by others is provided in accordance with the information furnished to the hollow metal manufacturer.

The hollow metal manufacturer is a material supplier, not a subcontractor. The manufacturer does not include the installation of their product in the building, but only shipment in good condition from the factory.

Should the General Contractor discover any error in the hollow metal delivered to the job site, it is imperative that the hollow metal manufacturer be notified in writing and allowed sufficient time before initiating any corrective measure in the field, so that the manufacturer can participate in solving the problem. Failure to do so could result in the cancellation of the warranty and/or fire label and non-acceptance of any cost associated with repair.

Most member companies of the Hollow Metal Manufacturer's Association Division of NAAMM have their own field representatives who are qualified not only to do expert repair work but to determine whether the fault lies with the manufacturer or with some other party.

It is essential that material is properly stored prior to installation and skills are exercised in the setting of frames and hanging of doors.

RELATED DOCUMENTS

- A. ANSI/A.250.11-2001 Recommended Erection Instructions for Steel Frames
- B. ANSI/NAAMM HMMA 801-05 Glossary of Terms for Hollow Metal Doors and Frames
- C. ANSI/NAAMM HMMA 841-07 Tolerances and Clearances for Commercial Hollow Metal Doors and Frames
- D. NAAMM HMMA 820-87 Hollow Metal Frames
- E. NFPA 80 Standard for Fire Doors and Other Opening Protectives 2007 Edition
- F. SDI-122-90 Installation & Troubleshooting for Standard Steel Doors and Frames

PART 2 - RECEIVING AND STORAGE OF MATERIAL

A. RECEIVING

Upon delivery, the contractor responsible for receiving hollow metal products shall thoroughly inspect for damage. Cardboard and other wrappings shall be removed for inspection and to promote air circulation. Any scratches or disfigurements caused in shipping or handling shall be promptly cleaned and touched up with a direct to metal rust inhibitive primer.

Should damaged material be found, the General Contractor has the option of refusing delivery or to accept the material as damaged. For coordination purposes, HMMA suggests that delivery should not be refused, but rather accepted as damaged. Any damaged items should be noted on the freight bill. Claims will not be honored by the freight carrier, unless the damaged items are noted on the freight bill at the time of delivery. The contractor shall notify the hollow metal manufacturer in writing immediately of any item signed for as damaged. The General Contractor must telephone or write the local office of the freight carrier and request an inspection of the damage. This procedure will help to expedite the repair or replacement of the damaged items and the processing of the damage claim with the freight carrier.

B. ON SITE STORAGE

Proper storage of hollow metal work at the construction site will help prevent damage to the primer coat of paint. Prime coated steel must be protected when exposed to the elements such as high humid-

ity, salt air, rain, snow, and/or damp wrappings etc.... Particular attention must, therefore, be given to steel products having a coat of factory applied primer. Primer is porous to properly receive and hold top coats. Water or moisture, in contact with primer coated steel will seep through to the steel. An electrolytic action then follows, resulting in corrosion and causing the paint film to lose adhesion. The presence of oxygen at the water-air interface behind the loosened paint film accelerates corrosive action and the prime coat further deteriorates.

Even when zinc coated steel is used to provide corrosion resistance, manufacturers of hollow metal door and frame products have found that one week of product exposure to water, due to improper storage, can be equivalent to at least a year of outdoor exposure to the elements.

NOTE: Paint manufacturers advise that the primer typically used by hollow metal manufacturers should receive a finish coat of paint within 30 days of delivery. It is the responsibility of the General Contractor to sand, touch up and clean prime painted surfaces prior to finish painting in accordance with the finish paint manufacturer's instructions.

The following procedures shall always be observed in storing hollow metal doors and frames at the job site:

1. Store all materials in a dry area, under cover. All products shall be stored where they will not be exposed to, or come in contact with the elements.
2. Do not use non-vented plastic or canvas. These materials create a humidity chamber, which promotes blistering and corrosion.
3. Store doors and frames in an upright position with heads uppermost, Figures 1 and 2.
4. Place no more than 5 doors or welded frames in a group. Small groups not only minimize the likelihood of damage due to excess handling, but also facilitate selection from the group for installation. In the case of multi-opening frames, no more than three units should be stored in a group, to avoid serious damage to the bottom most frame.
5. Place all material on planking or blocking at least 4 in. (100 mm) off the ground, 2 in. (50 mm) off a paved area or the floor slab.
6. Provide at least 1/4 in. (6.4 mm) space between all units to permit air circulation.

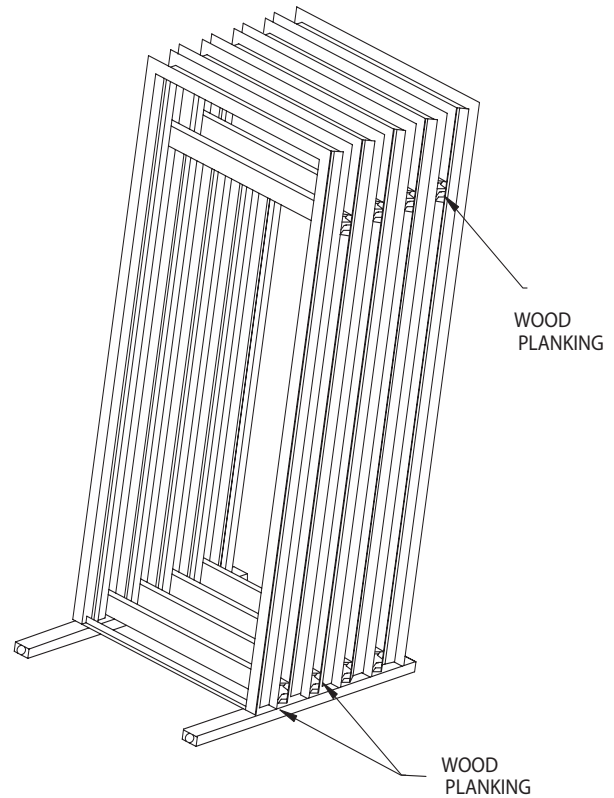

**FIGURE 1
FRAME STORAGE**

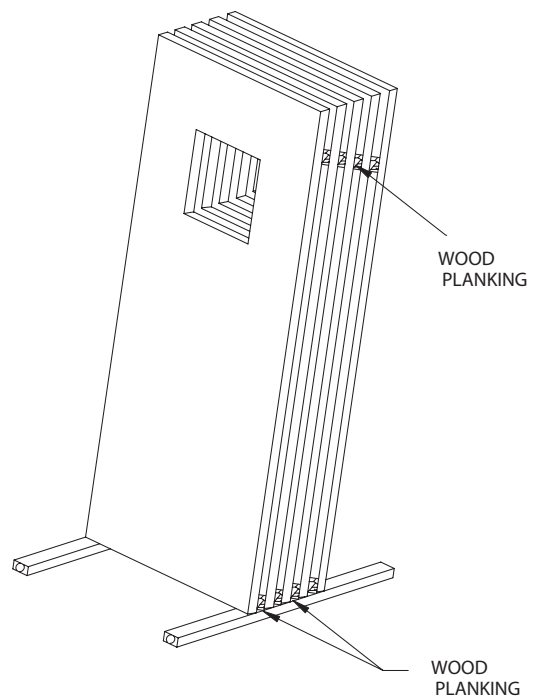

**FIGURE 2
DOOR STORAGE**

PART 3 - INSTALLATION OF FRAMES

A. GENERAL

Welded door frames are checked at the factory to ensure that they are square and that no jamb twists have occurred during fabrication. Temporary steel spreaders are then attached to the jamb base to minimize misalignment or other damage during handling and shipment. The frames are loaded on the carrier by personnel experienced in frame packing. The spreaders are for shipping and handling purposes only and must be removed before installing the frame.

At no time shall the spreaders be used during installation.

In spite of precautions, frames can and sometimes do arrive at the job site with minor alignment deviations. Minor deviations from true form and alignment can be corrected by the contractor responsible for installation.

When knock-down frames are used the manufacturer's recommended assembly procedures must be followed before installation of the frame can begin. A knock-down frame is easier to pack for shipment and requires less shipping space than a welded frame. Such frames, however, place greater responsibility on the installer, who must assemble them and make sure that, in spite of job conditions, they are square and in true alignment. Frames of this type normally use bendable tabs, screw or bolt fasteners in their assembly, and these may be lost in shipment or at the job site. In general, knock-down frames are not recommended for doors wider than 3 ft. 6 in. (1067 mm) or weighing more than 100 pounds (45 kg).

B. PRIOR TO INSTALLATION

The installer shall perform the following prior to installation:

The area of floor on which the frame is to be installed and the path of the door swing shall be checked for flatness and levelness. Permissible tolerance is +/- 1/16 in. (1.5mm). If the floor exceeds this, it is the general contractor's responsibility to correct the area that is out of tolerance before the frame is installed.

Frame shall be checked for correct size, swing, fire rating and opening number.

Remove temporary steel spreaders. Spreaders can typically be removed with cold chisel and hammer. With frame standing on concrete, position cold chisel at weld joint of spreader and jamb and strike chisel with hammer.

C. INSTALLATION TOLERANCES

During the setting of the frame, check and correct as necessary for opening width, opening height, squareness, alignment, twist and plumbness. Permissible frame product installation tolerances shall be maintained within the following limits: See Figure 3.

Opening width – Measured horizontally from rabbet to rabbet at top, middle and bottom of frame; +/- 1/16 in. (1.5mm).

Opening height – Measured vertically between the frame head rabbet and top of floor or bottom of frame minus jamb extension at each jamb and across the head; +/- 3/64 in. (1.2mm).

Squareness – Measured at rabbet on a line from jamb, perpendicular to frame head; not to exceed 1/16 in. (1.5mm).

Alignment – Measured at jambs on a horizontal line parallel to the plane of the face; not to exceed 1/16 in. (1.5mm).

Twist – Measured at opposite face. Corners of jamb on parallel lines, perpendicular to the plane of the door rabbet.

Plumbness – Measured at jambs on a perpendicular line from the head to the floor; not to exceed 1/16 in. (1.5mm).

The tolerances shown provide a reasonable guideline for proper installation of hollow metal frame products. However, it should be noted that the cumulative effect of the installation tolerances at or near their maximum levels could result in sufficient misalignment to prevent the door from functioning properly. Installers should be careful not to create a tolerance buildup. Tolerance buildup occurs when several tolerances are at or near their maximums. Care should be taken to keep each of these tolerances as close to zero as possible.

D. TYPICAL INSTALLATION PROCEDURES

Position frame in the correct location. Brace the frame as shown, Figure 4. Do not brace in the direction of intended wall.

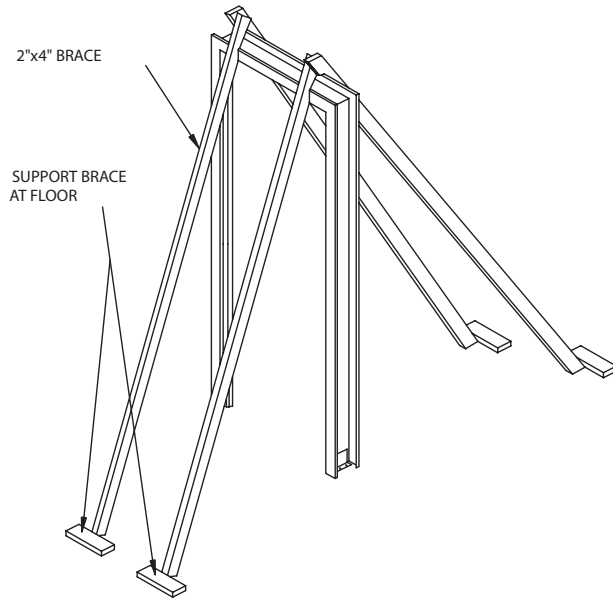

FIGURE 4
FRAME BRACING

With frame in position, install the temporary wood spreaders. The wood spreader, Figure 5, must be square and no less than 1 in. (25 mm) thick. Correct length is the door opening width between the jambs at the header. Cut clearance notches for frame stops. Spreader must be nearly as wide as frame depth for proper installation. Install a spreader at the bottom of the frame and a second wood spreader at the mid or strike point to maintain a proper door opening and to prevent bowing of the jambs, Figure 6. Clamp or wire spreaders to frame to hold spreaders in place until the frames are set permanently in the wall.

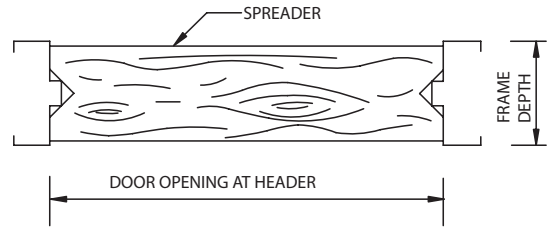

FIGURE 5
WOOD SPREADER

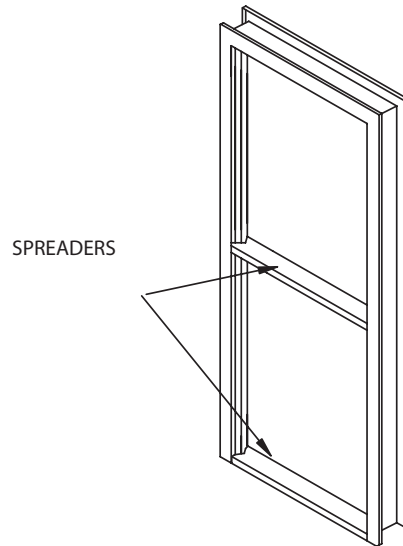

FIGURE 6
SPREADER LOCATION

At frames with jamb opening heights greater than 8 ft. (2438mm) or frame face dimensions less than 1-1/2 in. (38mm), install an additional wood spreader. Space wood spreaders at a maximum of 36 in. (914mm) intervals between header and bottom of frame, Figure 7.

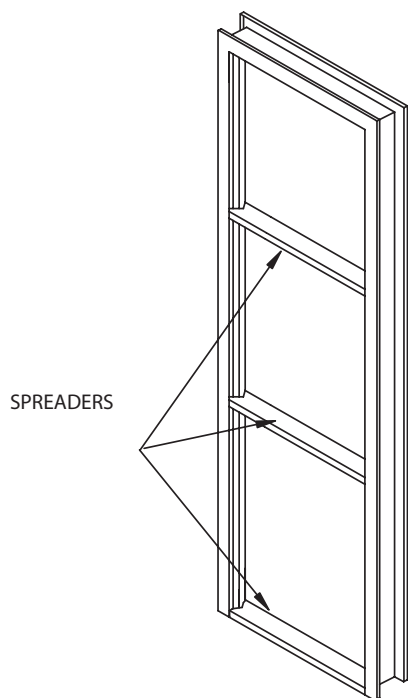

FIGURE 7
SPREADER LOCATION AT
LARGE JAMB OPENING HEIGHTS

At frames with sidelights where the sidelight sill intersects the door jamb near the strike, it is imperative that a wood spreader is located at this location, Figure 8.

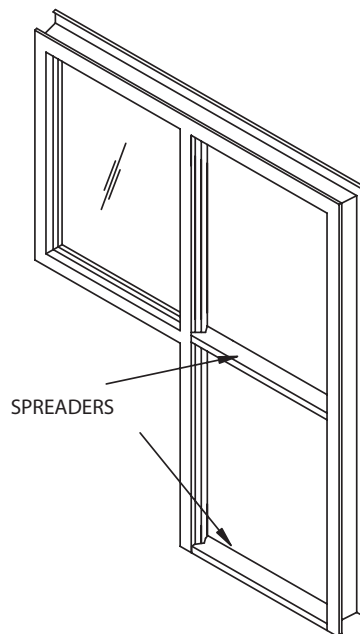
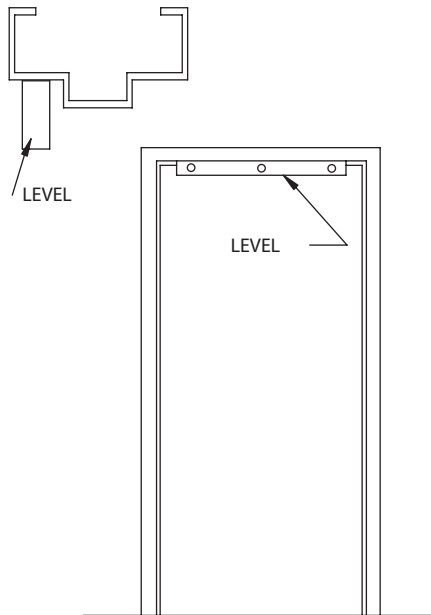

FIGURE 8
SPREADER LOCATION AT SIDELIGHTS

The installation contractor shall have a carpenter level and builder's square. Level the head by positioning the level to the head door rabbet, Figure 9. If necessary, adjust for high spots in floor by shimming under the jamb floor anchor, Figure 13a. Equalize them through an adjustable floor anchor, if specified, Figure 13b. Note, for labeled openings the maximum floor clearance is 3/4 in. (19mm).



**FIGURE 9
LEVELING THE HEAD**

With builder's square, check frame for squareness. Position square against jamb and head at door rabbet, adjust as required, Figure 10.

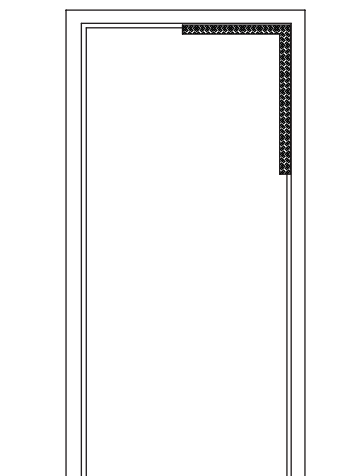

**FIGURE 10
SQUARENESS**

With carpenter level check the frame for plumbness and alignment: For plumbness, position level against both hinge and strike jambs in the rabbet. For alignment; Position level against both hinge and strike jambs on the stop, adjust as required, Figure 11.

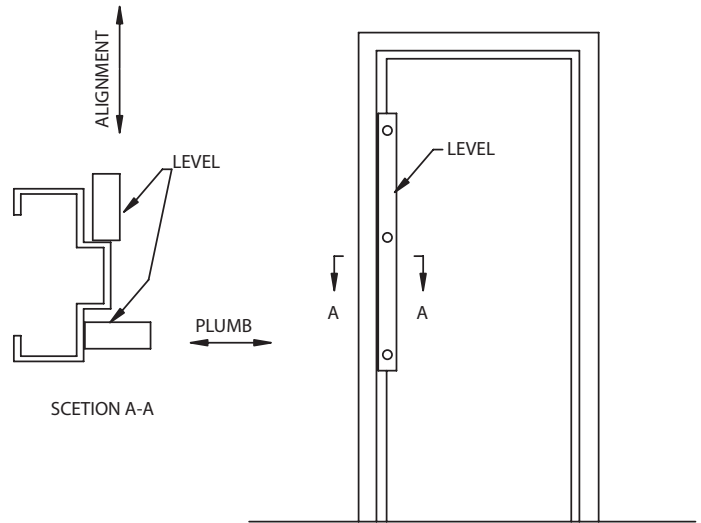

**FIGURE 11
PLUMBING AND ALIGNMENT**

With builder's square, check jambs for twist. Position square against door rabbet and project line perpendicular to the plane of the door rabbet, adjust as required, Figure 12.

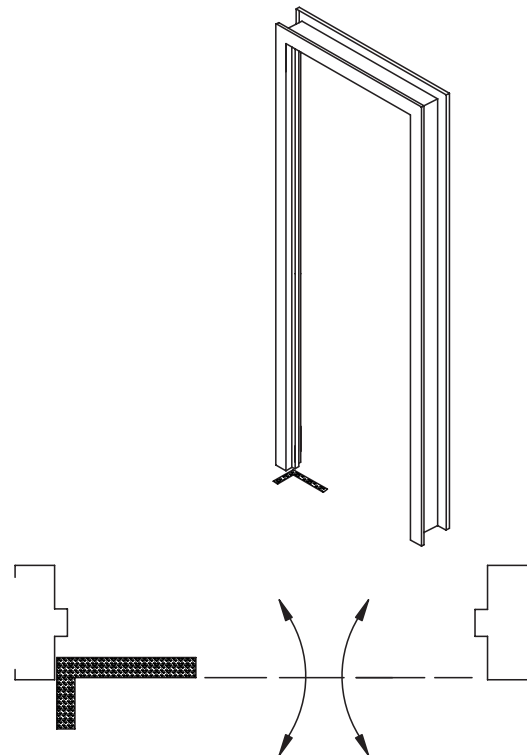
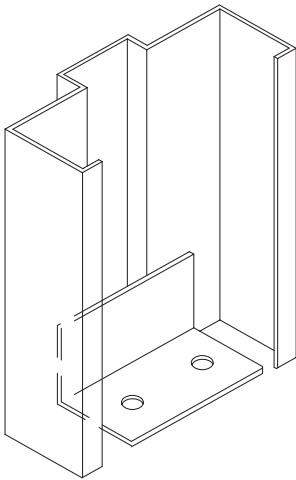

**FIGURE 12
FRAME TWIST CHECK**

Once the installer has ensured that the frame is in the correct position, anchor the jamb to the floor.

Floor Anchors: The fixed floor anchor is welded to the base of the jamb, typically secured to the floor by mechanical fasteners, providing solid anchorage for the base of each jamb, Figure 13a. Shimming must be used if the floor is not level. This type of anchor is not used in existing masonry, preframed stud walls or slip-on dry-wall frames, but may be provided.

At prepared openings (existing masonry or concrete) an additional expansion anchor reinforcement is provided. With pre-framed stud walls or completed drywall openings an additional base anchor is included. In both instances these anchors are located as close to the bottom of the jamb as is practical.



**FIGURE 13A
FIXED FLOOR ANCHOR**

The adjustable floor anchor is designed for use where there are significant irregularities from level, an intended slope in the floor, or where toppings such as terrazzo are used, Figure 13b. Like the standard anchor, it cannot be used in prepared openings or slip-on knock-down dry-wall frames.

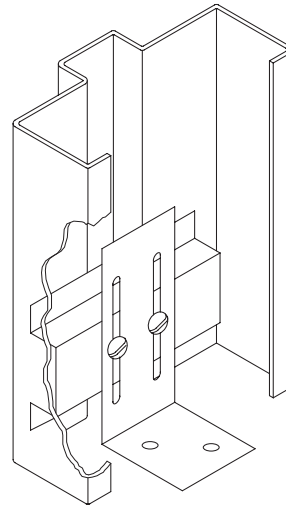

**FIGURE 13B
ADJUSTABLE FLOOR ANCHOR**

E. WALL CONSTRUCTIONS AND APPROPRIATE ANCHORS

Proper frame anchoring is vitally important to the proper performance of the door opening. A variety of jamb wall anchors are available to suit the various types of wall construction. Anchors shown on the following pages are but a few of the variety of anchoring methods available. For additional details, refer to HMMA 820 Hollow Metal Frames.

ANCHOR SPACING

Anchor Spacing: HMMA specifications require that the number of wall anchors used on each jamb, in all cases, be as follows:

- A. Openings in Masonry Walls. Frames with expansion bolt anchors; Anchors spaced a maximum of 6 in. (152 mm) from the top and bottom, with intermediate spacing at a maximum of 26 in. (660 mm) o/c. See Table 1.
- B. Openings in stud partitions with steel or wood stud anchors: Near hinges and directly opposite on strike jamb. See Table 1.
- C. Anchor quantity for slip-on drywall frames shall be as per manufacturer's standards and label requirements.
- D. Wall anchors locations and quantity are in addition to floor anchors, when required.

Table 1		
Frame Anchor Spacing		
Frame Height	Masonry Walls	Stud Partitions
> 0 in. < 60 in. (1524 mm)	2	3
> 60 in. < 90 in. (2286 mm)	3	4
> 90 in. < 96 in. (2438 mm)	4	5
> 96 in.	4 + 1 per 24 in. (610 mm)	5 + 1 per 24 in.

1. MASONRY WALLS

Installation of a hollow metal frame in masonry, Figure 14a. Refer to HMMA 820 Hollow Metal Frames for additional anchorage methods.

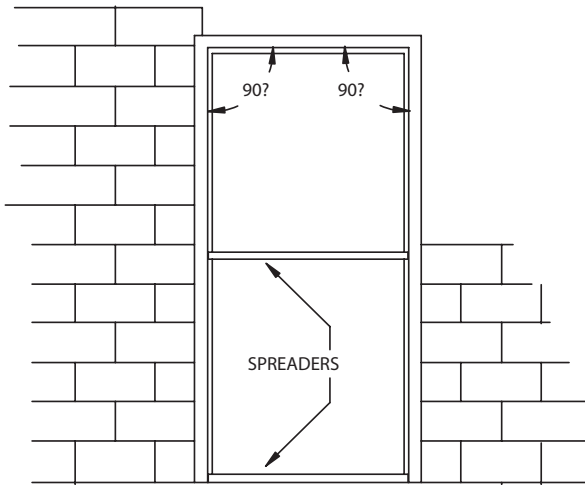

FIGURE 14A
MASONRY WALL

Adjustable strap-and-stirrup anchor, Figure 14b. A stirrup is welded to the back of the jamb, and a perforated or corrugated strap provides for embedding into masonry joints. The stirrup provides sufficient adjustment for masonry coursing as well as access for full grouting of jambs.

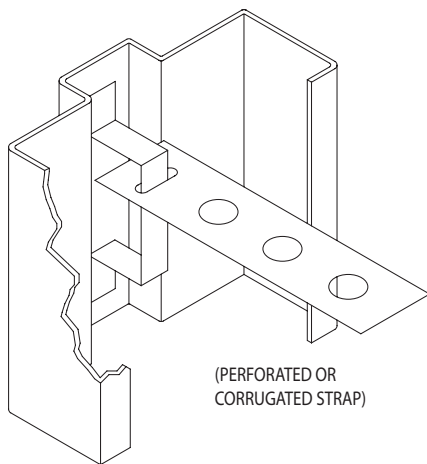

FIGURE 14B
STRAP & STIRRUP ANCHOR

T-strap anchor, Figure 14c and Wire Loop anchor, Figure 14d, function similar to the strap and stirrup anchor but are set loose inside frame returns as wall is laid up.

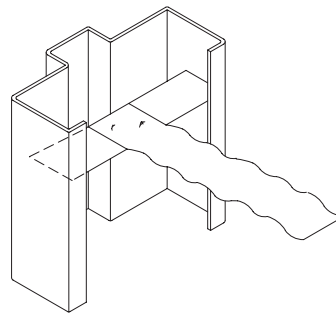

FIGURE 14C
T-STRAP ANCHOR

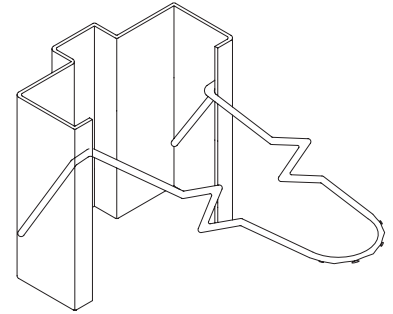

FIGURE 14D
WIRE LOOP ANCHOR

As wall is laid up, locate the anchors at the hinges in the hinge jamb and at a corresponding position in the strike jamb, Figure 14e.

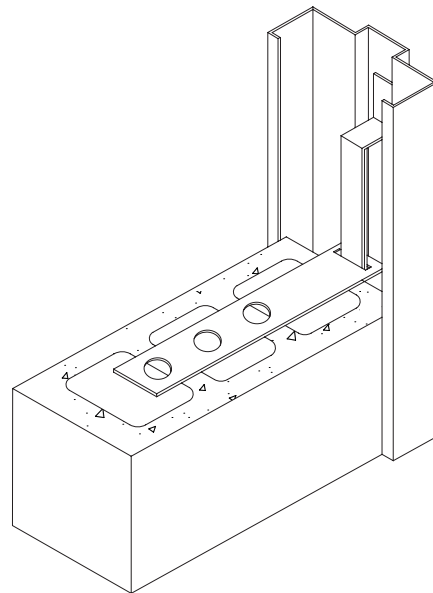

FIGURE 14E
MASONRY WALL WITH ANCHOR

Continually check squareness, plumbness, alignment, and twist in the frame as wall progresses.

2. STEEL STUD WALLS

Installation of a hollow metal frame in steel stud wall, Figure 15a. Refer to HMMA 820 Hollow Metal Frames for additional anchorage methods.

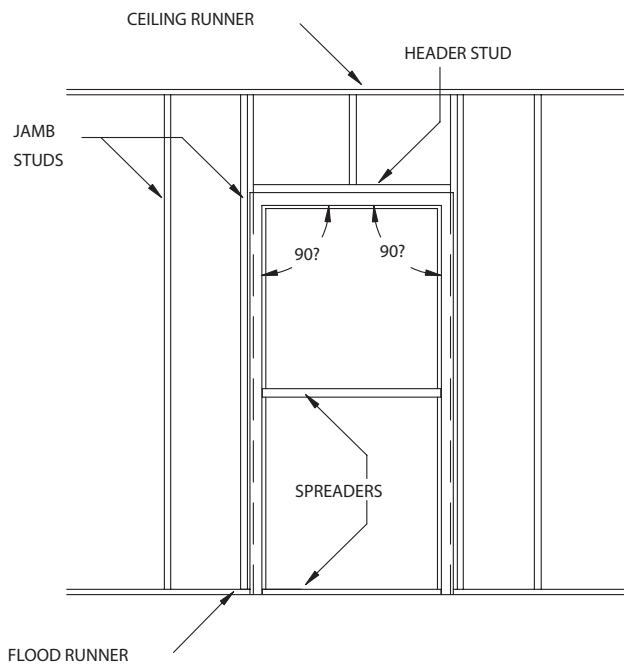

FIGURE 15A
STEEL STUD WALL

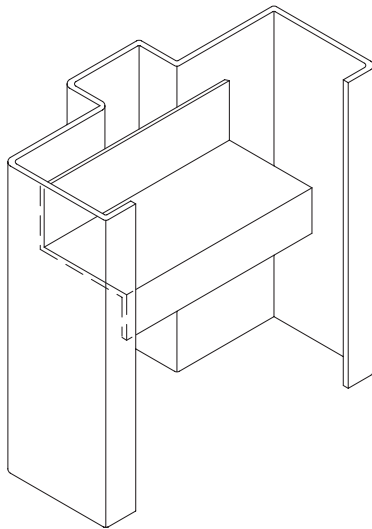

FIGURE 15B
ZEE SHAPED STEEL STUD ANCHOR

Zee shaped anchor, Figure 15b, is welded to both rabbets inside the jamb. Steel studs are mechanically fastened to the exposed flange through the throat of the stud.

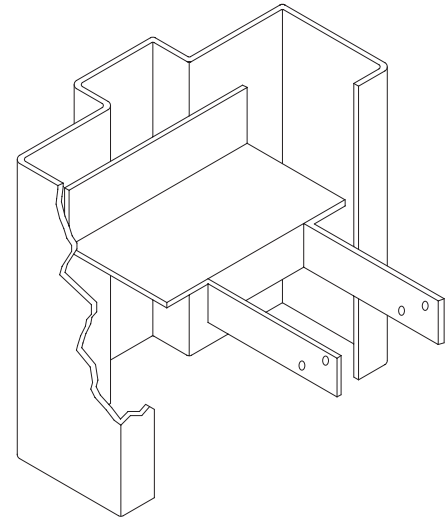

FIGURE 15C
COMBINATION WOOD/STEEL
STUD ANCHOR

Combination wood/steel stud anchor, Figure 15c, are welded or friction fit inside the jamb. Additional horizontal straps allows fastening to the face of the stud in lieu of through the throat. Typically used when the steel stud wall is assembled prior to setting the frame.

When fastening through the face of the stud, it is extremely important that the head height of fasteners are considered to ensure that the combined thickness of wall stud, fastener head height and finished wall material does not exceed the designed wall thickness. The effects of increased wall thickness will result in the frame faces being forced out during drywall installation, bowing the jamb profile. The corner between header and jamb will be visually bellied, and possible misalignment of frame may occur.

Due to this issue and with irregularities in wall construction width, it is strongly recommended that frames overlapping the wall, (except slip-on construction), have a throat dimension 1/8 in. (3.1mm) greater than dimensioned wall thickness.

Position the vertical steel studs in the frame throat opening in accordance with architect's details. Attach the vertical steel studs to floor and ceiling runners and fasten to the steel stud anchors with mechanical fasteners, Figure 15d.

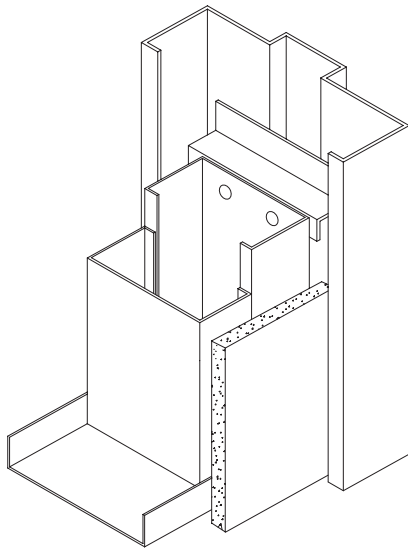

FIGURE 15D
STEEL STUD WALL WITH ANCHOR

Wall Construction: It is extremely important that the steel stud manufacturer's recommendation on thickness and general construction technique be followed to ensure that a solid and stable opening is achieved.

Figure 16a-d represents four methods of steel stud header connections to cripple studs above frame openings. Extreme precaution must be taken to ensure that any fasteners applied through face of studs or any construction will not increase the wall thickness.

Continually check squareness, plumbness, alignment, and twist in the frame as wall progresses.

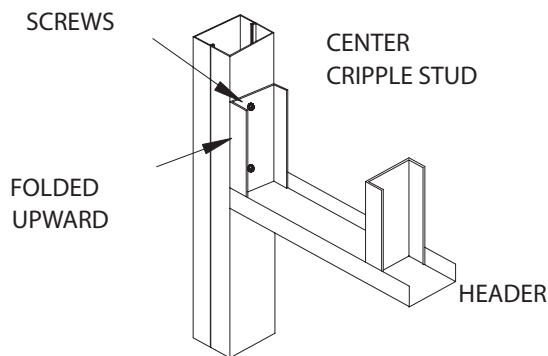

FIGURE 16A
RECOMMENDED

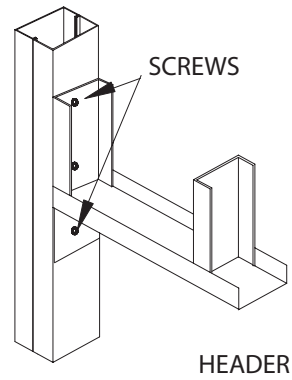

FIGURE 16B
ACCEPTABLE

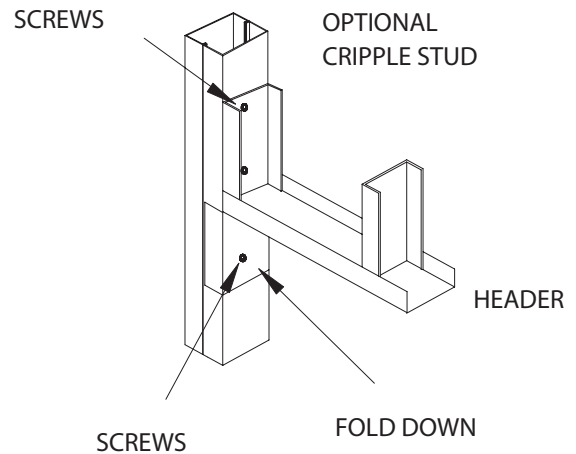

FIGURE 16C
NOT RECOMMENDED

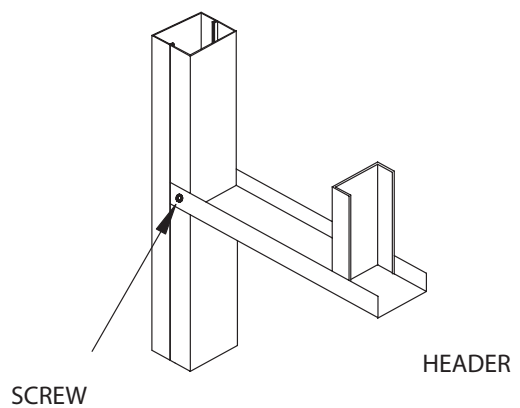

FIGURE 16D
NOT RECOMMENDED

3. WOOD STUD WALLS

Installation of a hollow metal frame in a wood stud wall, Figure 17a. Refer to HMMA 820 Hollow Metal Frames for additional anchorage methods.

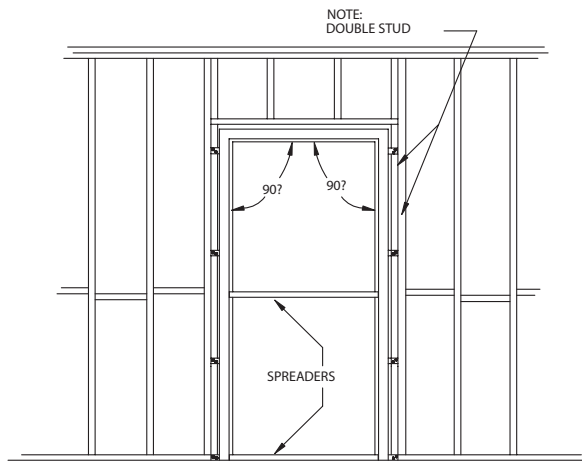

FIGURE 17A
WOOD STUD WALL

Wood stud walls can be constructed after the frame is set or prior to setting the frame. For constructing wall after the frame is set, follow guidelines same as steel stud walls. For constructing wall prior to setting the frame, follow these guidelines;

Rough Stud Opening:

- A. The width of the opening shall be the overall frame width plus 1/2 in. (12.7 mm).
- B. The height of the opening shall be the overall frame height plus 1/4 in. (6.4 mm).

Place the frame in the rough stud opening. Bend the anchor tabs around the stud, leaving the desired clearance between the frame return and stud, for inserting the finished wall material. Set the spreaders and level, plumb and align the frame. Check for twist in jamb. Shim by other and/or adjust as necessary

Square the frame at the top corner and nail the top anchor to the stud on ONE JAMB ONLY. Recheck the level, plumb and alignment of the frame at the other corner and continue to nail the balance of the anchors to the studs. Repeat the same process for the opposite jamb.

It is extremely important that the head of the fasteners are considered to ensure that the combined thickness of wall stud, fastener head height and finished wall material does not exceed the designed wall thickness.

Wood stud anchors, Figure 17b and 17c are welded to the back of the jambs. Figure 17d is either welded to back of the jamb or friction fit and available for wood or steel stud walls.

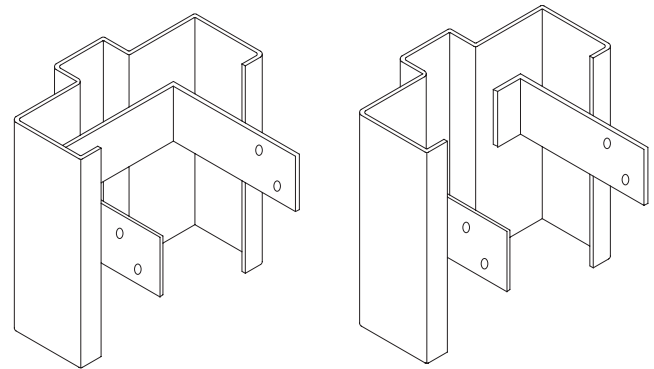

FIGURE 17B
WOOD-STUD ANCHORS

FIGURE 17C

FIGURE 17D
COMBINATION WOOD/STEEL
STUD ANCHOR

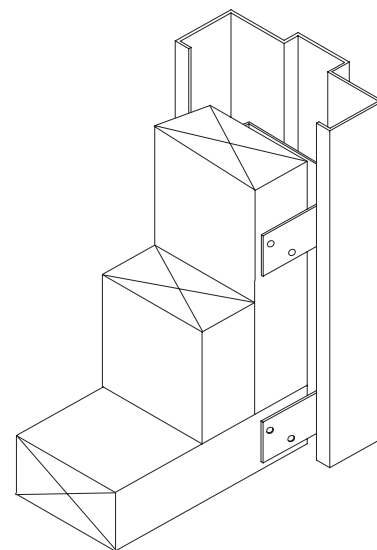

FIGURE 17E
WOOD STUD WALL WITH ANCHORS

4. EXISTING MASONRY WALLS

Refer to HMMA 820 Hollow Metal Frames for additional anchorage methods.

Clearance between existing wall and frame is critical in order to properly install frame. In addition to measuring the shortest dimension both vertically and horizontally, the existing opening must be checked for level and plumb. Size frame accordingly to dimensions taken providing 1/4 in. (6.3mm) clearance around frame.

Wall Preparation: Place the frame in the completed wall opening, Figure 18a. Check for squareness. Mark the wall through the holes in the jamb provided at the anchor points. Drill appropriate holes at the marks.

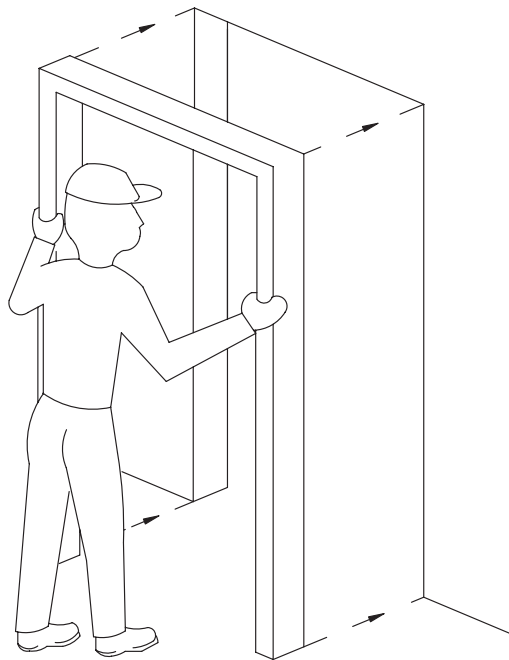

FIGURE 18A
EXISTING MASONRY WALL FRAME
INSTALLATION

Install frame: Insert mechanical fasteners through frame soffit into existing wall, Figure 18b. Shim, by others, behind anchors, above bolts to ensure a plumb frame.

The methods of plumbing the frame, and the use of the spreader noted under installation also applies to this wall condition. Tighten the screws. Caulk between frame and wall.

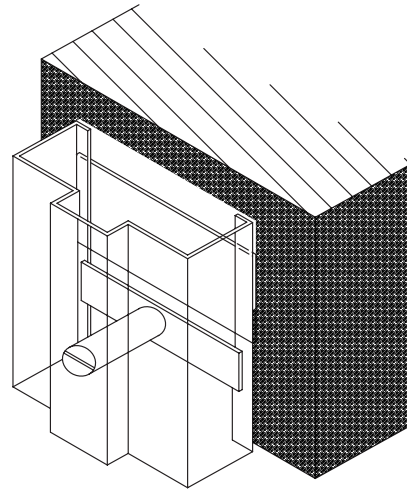

FIGURE 18B
EXPANSION BOLT INSTALLATION

Rough Buck Frame: Employ similar steps as described above when a Rough Buck is used, Figure 18c.

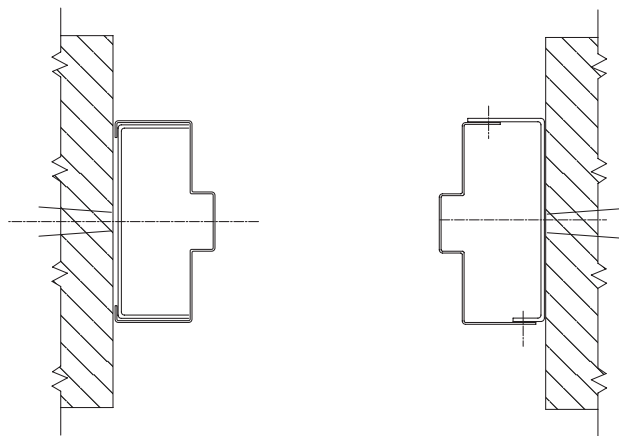

FIGURE 18C
ROUGH BUCKS

5. COMPLETED DRYWALL

Wall Construction: It is very important that the stud manufacturer's recommendation on thickness and general construction technique be followed to ensure that a solid and stable opening is achieved. For example, double studding at the opening is necessary; the header stud must be the same width as the jamb stud. It is particularly important that the overlapping of vertical and horizontal steel studs be avoided since this produces oversize walls. This could create significant installation problems when slip-on drywall frames are used.

Rough Stud Openings: A variety of anchoring techniques preclude the establishment of a definite rough opening standard. Follow the frame manufacturer's recommendations.

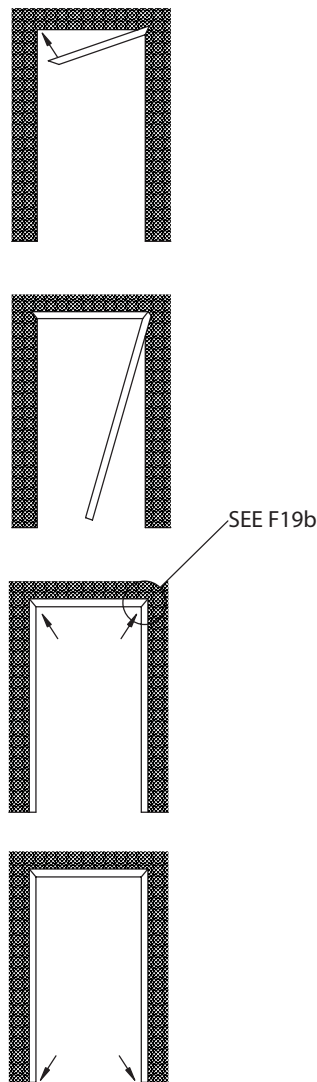

FIGURE 19A
INSTALLATION SEQUENCE

Installation Sequence: Installation varies from manufacturer to manufacturer. Consult the supplying manufacturer's literature for exact instructions. A typical installation cycle may be as follows, Figure 19a.

1. Slide the header in place over the wall approximately in the center of the opening.
2. Install one jamb by sliding it over the wall at the top. Push the bottom of the member until it is approximately vertical.
3. Install the other jamb in a similar manner. The frame should be installed with all excessive rough opening clearances thrown to the hinge side. The weight of the door will tend to cause movement, within the opening, toward the strike jamb.
4. Join the horizontal header to the jamba., Figure 19b . This is normally done by inserting tabs into the slots, or screws into the holes or a combination of both.

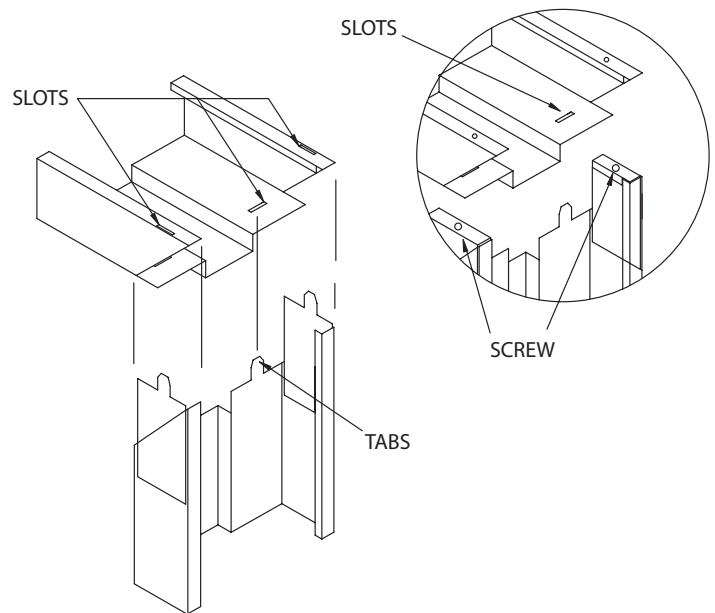

FIGURE 19B
CORNER CONNECTION
KNOCKDOWN SLIP-ON

Plumb and square the opening and check the jamba for twist. Some installers prefer to hang the door at this point, permitting the door to aid in performing this function.

Attach the base anchor to the stud or floor channel at the base of the wall.

The base anchor is usually a strap of metal, provided either welded or loose at each side of the jamb at the bottom with holes punched for nails or screws, Figure 19c.

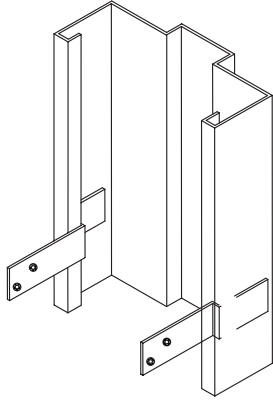

FIGURE 19C
SLIP-ON DRY WALL BASE ANCHOR

Compression Anchor, Figure 19d. An adjustable compression device is normally located near the top of each jamb. This anchor is used on slip-on dry wall frames and in conjunction with slip-on dry wall base anchors. Consult manufacturer's literature for direction to turn compression anchor. The compression anchor shall be hand tightened, do not use a screw gun.

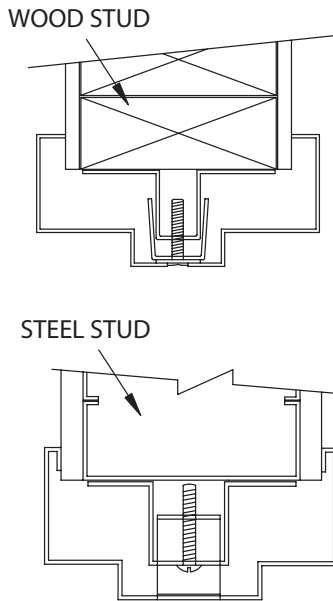

FIGURE 19D
COMPRESSION ANCHORS

F. GROUTING OF FRAMES

Grout guards and junction boxes are intended to protect hardware preparations and tapped mounting holes from masonry grout of 4 in. (100 mm) max. slump consistency which is hand troweled in place. If a lighter consistency of grout (greater than 4 in. (127 mm) slump when tested in accordance with ASTM C143) is to be used, special precautions must be taken in the field by the installation contractor to protect the hardware preparations. Any grout or other bonding material shall be promptly cleaned off of frames or doors following installation. Hollow metal surfaces shall be kept free of grout, tar or other bonding materials or sealers. Grouting materials which require air to dry (cure) are not recommended for such use in any closed section, such as a mullion.

When frames intended to be built into masonry construction which are prepared for silencers, the silencer must be installed prior to grouting to avoid filling the silencer hole.

See Appendix HMMA -820 TN01-03 "GROUTING HOLLOW METAL FRAMES"

G. FIELD SPLICING

When shipping and/or handling limitations so dictate, frames for large openings shall be fabricated in sections designed for splicing and welding in the field by others, Figure 20.

Field splices at labeled frames require either a mechanical or welded connection at each splice joint. Mechanical fasteners are through face of frame. If splice joints are welded, welds shall be ground smooth and immediately cleaned and painted with a compatible, direct to metal (DTM), rust inhibitive primer. For products fabricated from zinc coated steel, use zinc rich rust inhibitive primer.

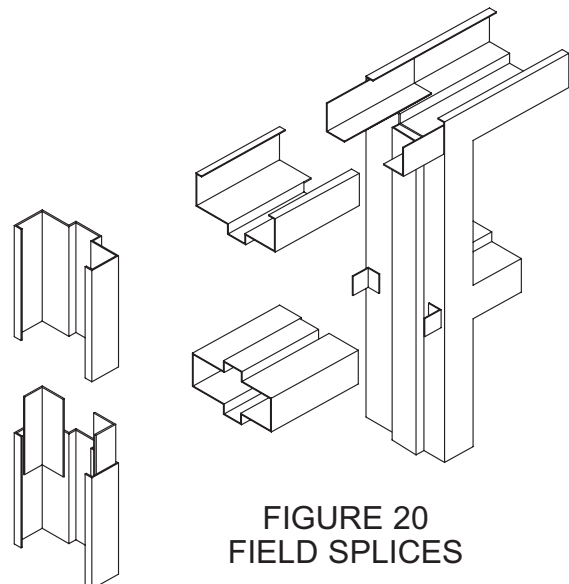

FIGURE 20
FIELD SPLICES

PART 4 - HANGING OF DOORS

A. GENERAL

It is the responsibility of the installer to hang all doors and install all hardware prior to finish painting. Doors shall be reinforced, drilled and tapped at the factory for templated mortise hardware only, in accordance with the approved hardware schedule and templates provided by the hardware supplier. Where surface mounted hardware, anchor hinges, thrust pivot, pivot reinforced hinges, or non-templated hardware apply, doors shall be reinforced, with drilling and tapping done in the field by others.

Experienced craftsmanship and care are essential in the hanging of metal doors. The use of steel hinge shims may be required to provide uniform clearance around the door and alleviate "hinge bind". Figure 21 and Figure 22.

The door-to-frame clearance adjustment toward the strike jamb (in the direction of arrow S) in Figure 21. can be accomplished by placing a metal shim or shims under the hinge leaf or leaves along the barrel edge of the hinge. Adjusting toward the hinge jamb (in the direction of arrow H) in Figure 22 can be done by placing a metal shim or shims under the outer edge of the hinge leaf or leaves.

B. OPERATION CLEARANCES

Edge clearances for swinging hollow metal doors and as specified in NFPA 80, shall be provided for the functional operation of the assembly and shall not exceed the following (for all door heights)

Between door and frame at head and jamb. 1/8 in. (3.1 mm) +/- 1/16 in. (1.5 mm)

Between edges of pairs of doors. 1/8 in. (3.1 mm) +/- 1/16 in. (1.5 mm)

Floor clearance for fire rated swinging hollow metal doors shall not exceed 3/4 in. (19mm). Floor clearance shall be provided for the functional operation of all swinging hollow metal doors and shall not be less than 1/8 in. (3.1mm)

The Architect must define the distance from the top of the floor / finished floor to top of floor covering so appropriate undercuts can be provided. Floor / Finish Floor is defined as the top of the concrete or structural slab. HMMA uses the term "top of floor covering" to describe the NFPA term "nominal surface of floor covering". Please refer to HMMA-810 TN01-03 Tech Note, "Defining Undercuts."

C. CARE AFTER INSTALLATION

Doors installed prior to completion of construction may be subject to damage from other trades because of improper protection or carelessness on the part of construction workers.

Prime or painted surfaces which have been scratched or otherwise marred during installation (including field welding) and/or cleaning, shall promptly be finished smooth, cleaned, treated for maximum paint adhesion, and touched up with a direct to metal (DTM), rust inhibitive primer.

Acid washing of masonry construction adjacent to door and frame installations will damage the steel surfaces whether primed or finish painted.

If not cleaned immediately, rusting will occur. For this reason steel doors and frames must be protected. If exposed to an acid wash, all primed or painted steel surfaces must be thoroughly cleaned with particular attention being given to hidden areas such as those areas under glazing stops.

For additional information regarding the painting of hollow metal products, please refer to HMMA-840 TN01-07 Tech Note, "Painting Hollow Metal Products"

USE HINGE SHIMS TO ADJUST DOOR CLEARANCE

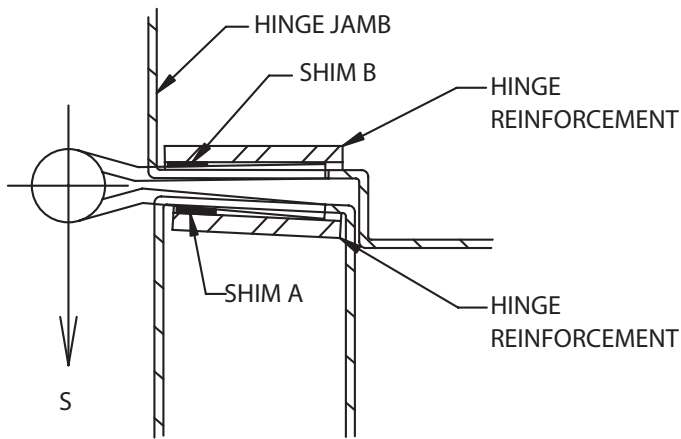

FIGURE 21
SHIMMING TO INCREASE
CLEARANCE AT HINGE EDGE

Using shim A only, door will be relocated in direction of arrow S.

Using shim B only, both door and centerline of hinge barrel will move in direction of arrow S.

Using both shims A and B will move the door further in direction of arrow S than by using either A or B alone, and hinge barrel will be relocated just as using B alone.

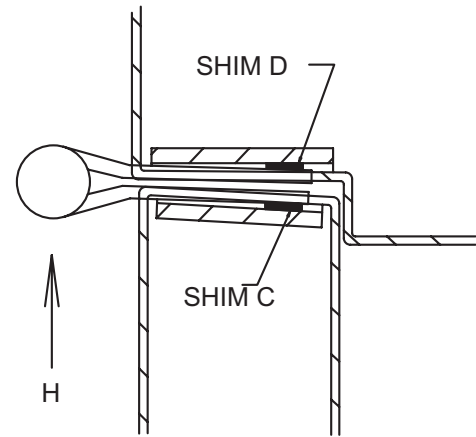

FIGURE 22
SHIMMING TO DECREASE
CLEARANCE AT HINGE EDGE

Using shim C only, door will be relocated in direction of arrow H.

Using shim D only, Both door and centerline of hinge barrel will move in direction of arrow H.

Using both shims C and D will move the door further in direction of arrow H than by using either C or D alone, and hinge barrel will be relocated just as by using D alone.

APPENDIX 1
(Not part of the Standard)



HMMA-820 TN01-03



Grouting Hollow Metal Frames

Grout, when used in accordance with industry guidelines, can improve frame durability, sound deadening, and, depending on wall construction, increase frame anchorage strength. Grouting of the frame does not increase door durability, nor is it required for fire-rated frames. For most commercial applications, grouting of mullions and other closed sections is not recommended.

For applications covered by ANSI/NAAMM HMMA 862, “Guide Specifications for Commercial Security Hollow Metal Doors and Frames,” and ANSI/NAAMM HMMA 863, “Guide Specifications for Detention Security Hollow Metal Doors and Frames,” the standards require that “frame jambs shall be fully grouted to provide added security protection against battering, wedging, spreading, and other means of forcing open the door”.

Grout is a water-based product. If not used properly, it can destroy the opening in a very short time. Grout can be either “mortar”, which is a masonry mixture of lime, cement, sand, and water, or “plaster”, which is a gypsum-based product.

Plaster grout dries by exposure to air. When a frame member is filled solid with plaster grout, only those areas exposed to air will dry and harden, while the center remains wet (uncured). The water remaining in the plaster grout can rust the frame from the inside. Plaster grout should not be used.

Mortar grout cures by chemical reaction and hardens throughout. Use mortar grout.

Frames are not designed to act as forms for grout. Grout must have a maximum 4 in. slump and be hand troweled in place. Bracing of the frame may be necessary prior to grouting to prevent sagging of the header or bowing of the jamb due to weight or pressure of the grout. Grout should not be installed after gypsum wallboard is installed, as the liquid within the grout will deteriorate the wallboard.

When dictated by temperatures, anti-freezing agents for mortar may be recommended by specifications. These agents can adversely affect metal, and all surfaces in contact with the grout must be coated with a corrosion resistant material.

It is recommended that the contractor be responsible for the grouting and for any required barrier coating. It is also his responsibility to use care in the application of the grout.

APPENDIX 2
(Not part of the Standard)

H M M A

TechNotes

HMMA-810 TN01-03



Defining Undercuts

Review of established definitions.

1. **“ACTUAL DOOR HEIGHT”** – The door opening height minus top clearance and undercut.
2. **“DOOR OPENING HEIGHT”** – The distance measured vertically between the frame head rabbet and top of floor or bottom of frame minus jamb extension.
3. **“FINISHED FLOOR”** – See “Floor”
4. **“FLOOR”** – The top of the concrete or structural slab.
5. **“FLOOR CLEARANCE”** – The distance between the bottom of the door and the top of the material directly below the door. This varies with application, such as concrete, any floor covering and/or a threshold.
6. **“FLOOR COVERING”** – Any material applied on top of the floor that extends under the door in its closed position or under the door as it swings to its fully open position.
7. **“UNDERCUT”** – The distance between the bottom of door and the bottom of frame. The formula in which to determine Undercut is derived by adding the total sum of the following (Floor Clearance + Floor Covering Thickness + Threshold Height (assuming the threshold is mounted on top of the floor covering) + Jamb Extensions Height).
8. **“JAMB EXTENSIONS”** – That portion of a jamb or mullion which extends below the level of the floor.

Typically frames are intended to be installed directly on the floor. When no floor coverings or thresholds are used, the dimension for “Undercut” is the same as for “Floor Clearance.” See Figure #1.

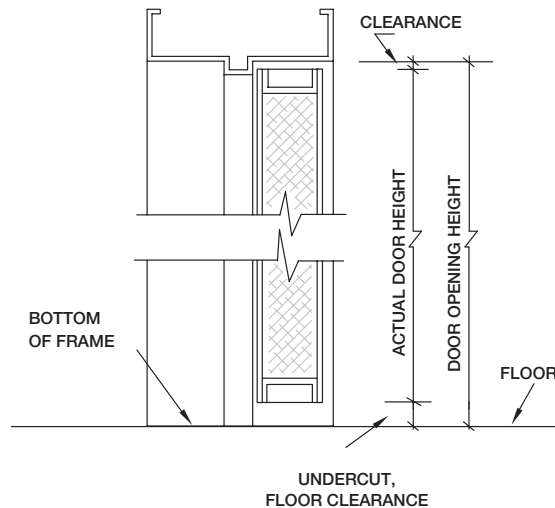

Figure #1

Floor coverings, such as carpet, resilient or ceramic tile, are typically installed on top of the floor, fitted around the frame, and under the door. In this situation, the formula for figuring Undercut is the total of the Floor Clearance + Floor Covering Thickness. See Figure #2.

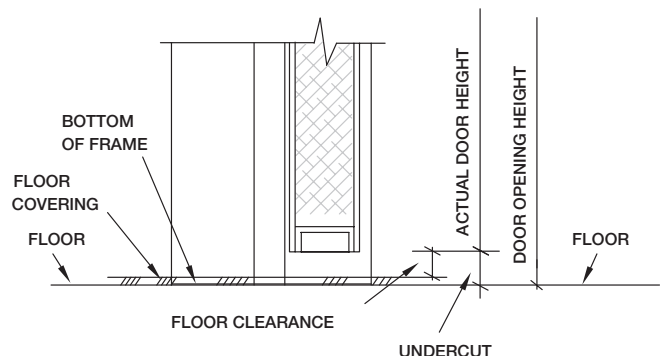

Figure #2

When a threshold is used, it is installed on top of the floor or floor covering, fitted around the frame and under the door. Again the formula for figuring “Undercut” changes. Undercut is the total of the

Floor Clearance + Threshold Height + Floor Covering Thickness. See Figure #3.

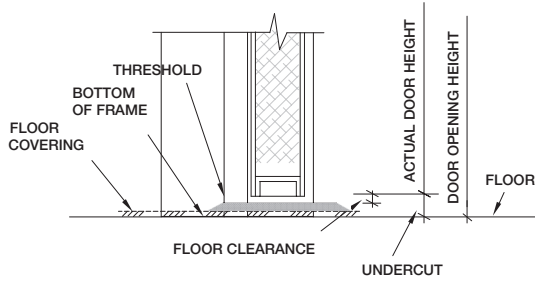

Figure #3

In situations with specialized floors such as thick ceramic tile or terrazzo, the frame is typically installed prior to the installation of the floor.

One method is to install the frame with adjustable floor anchors or for the frame to be installed on a block or shim. This allows the frame to be positioned, as required, to accommodate the floor height. See Figures #4A and #4B. Both illustrate a raised frame condition in which the bottom of frame is positioned to be directly on top of the floor after the floor is installed. In this situation, the dimension measured for Undercut is also the same as Floor Clearance.

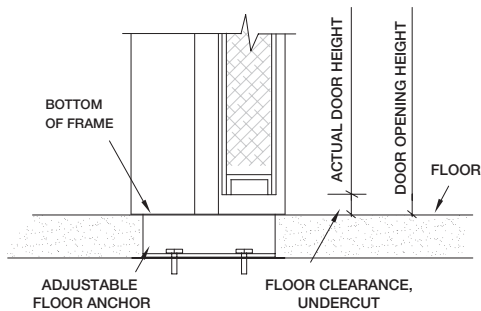

Figure #4A

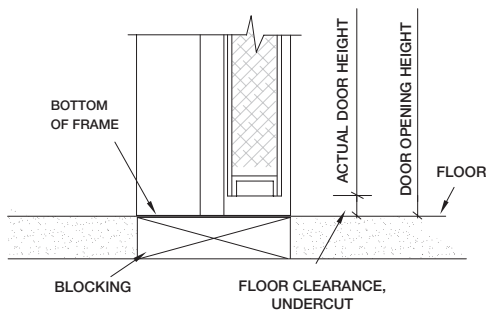

Figure #4B

Another method, called “below floor installation,” is to install the frame directly on the rough slab. After the frame is installed, the floor is then installed around the frame. That portion of the

frame that is covered by the floor is called jamb extensions. The formula for figuring “Undercut” is the total of the Floor Clearance + Jamb Extensions. See Figure #5A and #5B.

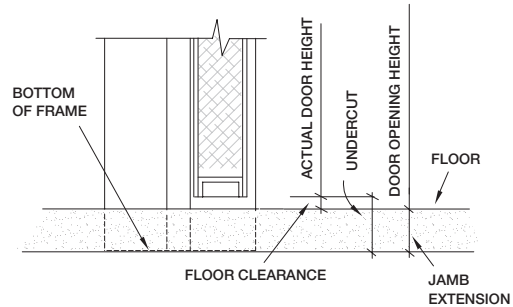

Figure #5A

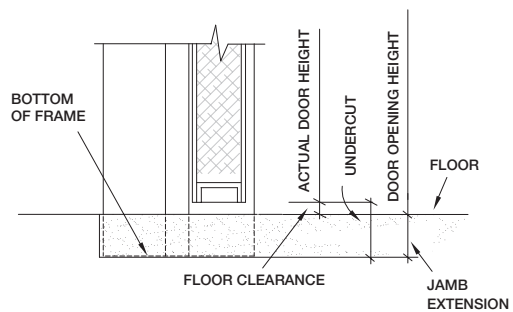

Figure #5B

The Architect/Designer must be very specific within specifications and contract drawings, which should include detailed drawings illustrating conditions for each floor, including thicknesses and materials. These drawings should designate the height at which the hollow metal frame should be set. Thresholds and hardware items requiring specific floor clearances shall be listed in the hardware schedule, which allows the door and frame manufacturer to properly size each opening.

Within the door and frame industry, both the Hollow Metal Manufacturers Association (HMMA) a division of the National Association of Architectural Metal Manufacturers (NAAMM) and the Steel Door Institute (SDI), publish recommended clearances. In addition, the National Fire Protection Association (NFPA) Publication 80, “Standard for Fire Doors and Fire Windows,” regulates the installation and maintenance of labeled openings, and lists several different scenarios consisting of different floor material and the maximum clearance under the bottoms of doors.

APPENDIX 3
(Not part of the Standard)



HMMA-840 TN01-07



Painting Hollow Metal Products

Hollow metal doors, frames, and related products are fabricated from hot-rolled, cold-rolled, zinc-coated, or stainless steel. Stainless is typically not painted and therefore not referred to in this tech note. Hot and cold-rolled steel are supplied either dry or oiled and require treatment prior to painting. Zinc coated steel is either galvanized or galvanized. Galvanized steel is manufactured suitable for immediate painting without further treatment other than normal cleaning. Galvanized steel requires treatment prior to painting. Refer to HMMA 802, “Manufacturing of Hollow Metal Doors and Frames” for more information.

Hollow metal products must be stored in a manner to prevent exposure to adverse environmental elements. Refer to HMMA 840, “Guide Specifications for Installation and Storage of Hollow Metal Doors and Frames” for more information. Primer protects the uncoated base metal and provides the bonding agent required for the finished paint. It is very important that the primer is protected and cleaned prior to the application of the finish coat of paint. Primer manufacturers advise that the primer receive a finish coat within 30 days of delivery.

Exposure to elements, such as high humidity, salt air, snow, rain, damp wrappings, etc., without proper protection and air circulation, allows moisture to be absorbed by the primer. Once this occurs, with the presence of oxygen, an electrolytic action follows. Moisture travels between primer and the metal surfaces in a capillary action, deteriorating primer adhesion. Eventually this can result in water stains, rusting, flaking, lifting, or peeling. When paint flakes, lifts, or peels, rusting is not always evident. Typically these areas have not been in constant contact with the elements, but moisture has traveled under the primer.

Breakdown of the primer adhesion can be caused by incompatibility with the finish coat of paint resulting in the same conditions as listed above. Care must be taken to ensure compatibility of primer and any top coat. A small area test is always recommended to verify compatibility and adhesion. In some instances, a barrier coat between primer and top coat is necessary. Consult finish paint manufacturer’s instructions.

Different paint problems have different solutions. Depending on the severity of the problems, sanding, sanding to bare metal, cleaning to remove contaminants, and re-priming can be necessary.

The selection of paint is also a consideration. Manufacturing marks are not always visible with a flat low gloss primer but can appear after a gloss finish coat is applied. The use of high gloss paint will increase the show through tendencies and is not recommended. A maximum paint gloss rating of 20 % reflectance, measured using a 60 degree gloss meter, would be the standard recommendation. Select a commercial direct to metal, (DTM) quality paint.

It is extremely important to follow the finish paint manufacturer’s instructions. It is important to avoid painting in extremely hot, cold, or damp weather. Ensure material being painted is clean and dry. Prior to finish painting, lightly sand primed surfaces with fine grit sand paper or emery cloth.

RECOMMENDED GUIDE SPECIFICATIONS FOR HMMA HOLLOW METAL DOORS AND FRAMES

HMMA 860 — Hollow Metal Door and Frames

ANSI/NAAMM

HMMA 861 — Commercial Hollow Metal Doors and Frames

ANSI/NAAMM

HMMA 862 — Commercial Security Hollow Metal Doors and Frames

ANSI/NAAMM

HMMA 863 — Detention Security Hollow Metal Doors and Frames

ANSI/NAAMM

HMMA 865 — Swinging Sound Control Hollow Metal Doors and Frames

ANSI/NAAMM

HMMA 866 — Stainless Steel Hollow Metal Doors and Frames

ANSI/NAAMM

HMMA 867 — Commercial Laminated Core Hollow Metal Doors and Frames